

General Purpose, Shrinkage Compensated Cement Based Grout

Guardian GPCG is a non-shrink cementitious grout designed for grouting applications where it is necessary to eliminate shrinkage whilst completely filling the gap between the substrate and the base plate. Guardian GPCG was designed for use in local conditions and therefore has extended working times. Guardian GPCG complies to ASTM C1107, Type A.

USES & ADVANTAGES

Guardian GPCG is a general purpose grout suitable for the following grouting works; cavities, gaps, columns in precast construction cavities, large cavity concrete repair with aggregates. It may also be used for repairs such as tied holes and honeycombs in trowellable form.

Advantages include:-

- Expansion system eliminates shrinkage in plastic state.
- Non Metallic.
- Only requires addition of water.
- Good early and ultimate strength.
- Low permeability.
- Excellent flowability.
- Use for concrete repair work.
- Chloride free.

PROPERTIES

Appearance:	Grey powder
Bulk Density:	Approx. 1.40-1.50 kg./litre
Minimum gap width:	5 mm.
Yield:	Approx. 74 - 76 x 25 kg/bags/m ³
Water by weight of Grout:	15.5 – 16 %
Bond Strength to Concrete:	> 2.5 N/mm ² at 28 days (Concrete failure) ASTM D 4541
Drying Shrinkage:	< 500 micro strain
23°C C/RH 50%	at 28 days ASTM C 490
Resistivity:	< 12,000 ohm cm at 28 days

*Properties are typical under laboratory conditions and do not constitute a specification. Field trials are recommended.

SURFACE PREPARATION

Surfaces should be clean sound and free from oil, grease, laitance and loose particles. Metal surfaces should also be clean and free of rust, oil, grease and contaminants

FORM WORK

The formwork should be watertight. Therefore a joint sealant should be used to close all points where forms meet and also around the bottom and top of formwork.

PRE-SOAKING

The prepared areas should be flooded with water for 3- 4 hours prior to the placement of Guardian GPCG. Immediately before the grout is placed all free water should be released from the area to be grouted. There should be NO standing water present when the grout is placed.

General Purpose, Shrinkage Compensated Cement Based Grout

MIXING

Guardian GPCG should be mixed using a suitable mixer. For flowable consistency use a hand drill and paddle with a speed of <400 R.P.M. For large works use a high shear vane grout mixer. Drum mixers are not recommended.

The entire contents of the bag should be added to the pre-measured (3.87-4.00 litres) water while mixing.

DO NOT add more than the maximum water content.

APPLICATION

Ensure the substrate is prepared according to the manufactures recommendations. No free water should be present in the area to be grouted. Ensure that there is sufficient air release holes for entrained air to escape. Mortar should be continuously poured, from one side only, until the gap is completely filled. Maintain continuous head of grout when pouring.

IMPORTANT NOTES

Depending on the volume to be filled, large aggregates, eg. 4-8 mm, 8-16 mm or 16-32 mm may be added to the **Guardian GPCG** at ratio of between 50-100% by weight. The aggregate should be sound, clean and pre saturated with water. Round aggregates are more suitable than crushed. Vibrate to ensure good com- paction.

CURING

To prevent premature surface drying and crazing, cure exposed areas or other approved method.

PACKAGING

4 Ply. 25 kg. plastic lined bags.

STORAGE & SHELF LIFE

Store in dry shaded conditions. The shelf life is at least 12 months if kept dry in original packaging. High temperatures and humidity may reduce shelf life.

HEALTH & SAFETY

Guardian GPCG is alkaline avoid contact with skin & eyes. Gloves, goggles and dust mask should be worn. Remove from skin with soapy water. Splashes in the eyes should be washed out with copious amounts of clean water and medical attention sought.

Guardian GPCG is non-flammable.

TYPICAL CHARACTERISTICS AT 25°C UNDER LABORATORY CONDITIONS

Water Content (%)	Consistency (J rote)	Setting time@25oC (minutes)		Bleeding ASTM C940 ASTM C232	Average Compressive Strengths (N/mm ²) - ASTM C109			
		ASTM C191-01a/ ASTM C807			1 day	3 days	7 days	28 days
		Initial	Final					
16.0	8-12 seconds	300	360	0	35	40	50	65
13.0 –14.0	Trowellable	220	270	0	40	45	55	65-70

General Purpose, Shrinkage Compensated Cement Based Grout

Typical hopper set up for grouting with Guardian GPCG

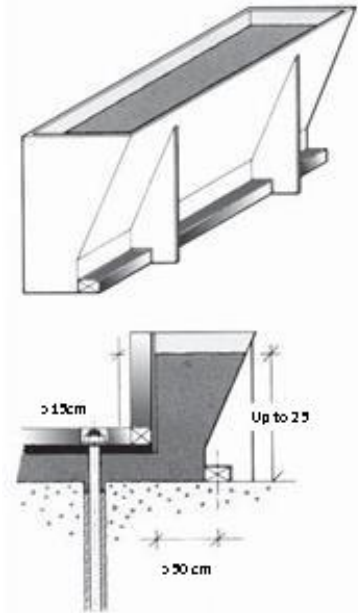

20 mm thick plywood

50 x 75 mm timber bolted to substrate

TECHNICAL SERVICE

The Guardian Coating Service Department is available to assist you in the correct use of our products and its resources are at your disposal entirely without obligation.

QUALITY ASSURANCE (OEM)

ISO 9001 : 2015 verified by TUV Nord

All statements and data presented herein are given in good faith and believed to be appropriate and reliable. It is given without express or implied warrant or guarantee. Potential users of Guardian's materials are urged to conduct confirmatory trials to satisfy themselves as to the suitability of the selected product for their particular end use prior to purchase.